

HECHA Intelligent Equipment CO., LTD

✉ : info@hechalifttruck.com

☎ : +86 158500 52055

📍 : No.8 Dongxi Road, Pinghu City,
Zhejiang Province, China



HECHA LIFT TRUCK

www.hechalifttruck.com



HECHA Diesel Forklift FD Series

HECHA
LIFT TRUCK

Enjoy Easy Lifting

HECHA Intelligent Equipment CO., LTD reserves the right to make any changes without notice concerning colors, designs, or detailed specifications in this brochure.



Representantes para Colombia y Ecuador
Calle 35 B sur 72L 61
Bogotá D.C - Colombia
www.mixingyequipos.com
+57 (601)-7048674 / +57 - 313 715 1638
/ 320 492 5574 / 320 900 3321

HECHA Intelligent Equipment CO., LTD



Diesel Forklift

**Strong and Durable,
Excellent Solution when Applied Outdoors**

What's your imagination for a diesel forklift? Durable, reliable, powerful, or efficient? Whatever your imaginations, diesel forklifts from HECHA will perfectly match your expectation.

Our forklifts are young but reliable, with years of development, HECHA forklifts keep delivering quality, productivity, and efficiency. You will never imagine the lifting in your warehouse or production facilities will be so easy, reliable, and cost-effective before meeting our products.

A high-quality diesel forklift is an essential component for your intralogistics solution. The low-noise diesel forklifts work perfectly in outdoors and can easily be operated on uneven surfaces.

Our diesel forklift is extremely ergonomic, offering the utmost reliability for goods transport, both indoors and outdoors goods transport. They are capable to handle loads weighing up to 15 tons.

Maybe it's your first time purchasing a forklift from overseas, and you'll be confused when choosing from the numerous engines or options. Please kindly don't worry, whatever your requirements are, our team will work with you together to find the perfect forklift to suit your needs.

With a choice of engines and options, we will always find a suitable solution to facilitate your intralogistics, thus help you save time and cost.

Let's say goodbye to the tough warehouse work and **Enjoy Easy Lifting** together!



Technical Features

Excellent Visibility:

The new compact mast has greatly improved the visibility, providing the driver with excellent views of the load and the operating environment.

Ergonomic Design:

Operator and machine working as one. The operator can operate all control elements with minimum effort and utmost precision.

Powerful Engines:

The powerful and time-tested engine helps guarantee excellent driving dynamics with low emissions.

Perfect Combination of Power and Capacity:

Our FD Series diesel forklifts carry loads ranging from 1.0 to 5.0 tons while ensuring rapid turnaround and the utmost efficiency in your warehouse or production facility.



Robust in Every Way:

Unrivaled for maneuverability, whether making quick changes of direction, dynamic acceleration, rapid reversing, or precise positioning - the modern drive technology guarantees maximum driving comfort and the highest throughput.

Heat Dissipation:

With the optimized cooling system and great cooling performance, the service life of many key parts like transmission and engine has been greatly improved.

Serviceability:

The perfect serviceability is well guaranteed via a wider internal pace, the reasonable parts layout and a larger hood opening angle.

Genuine Cost-effectiveness:

Our FD Series diesel forklifts offer both powerful performance and genuine cost-effectiveness.



Technical Parameters

| Characteristics | | | | | | | |
|--|---|---------|--------------------------------|--------------------------------|--------------------------------|----------------------------------|----------------------------------|
| 1.1 | Model Name | Metric | FD10 | FD15 | FD18 | FD20 | FD25 |
| 1.2 | Power Source | | Diesel | Diesel | Diesel | Diesel | Diesel |
| 1.3 | Rated Capacity | kg | 1000 | 1500 | 1800 | 2000 | 2500 |
| 1.4 | Load Center | mm | 500 | 500 | 500 | 500 | 500 |
| Dimensions | | | | | | | |
| 2.1 | Mast Extended Height (with Brackrest) | mm | 4065 | 4065 | 4065 | 4060 | 4060 |
| 2.2 | Lifting Height | mm | 3000 | 3000 | 3000 | 3000 | 3000 |
| 2.3 | Mast Height, Lowered | mm | 1995 | 1995 | 1995 | 2060 | 2060 |
| 2.4 | Free Lift Height | mm | 100 | 100 | 100 | 140 | 140 |
| 2.5 | Backrest Height (Calculated from the Fork Surface) | mm | 1015 | 1015 | 1015 | 1010 | 1010 |
| 2.6 | Distance from the Surface of the Seat to the Overhead Guard | mm | 1030 | 1030 | 1030 | 1035 | 1035 |
| 2.7 | Overhead Guard Height | mm | 2070 | 2070 | 2070 | 2090 | 2090 |
| 2.8 | Overall Length (without Forks) | mm | 2170 | 2260 | 2260 | 2475 | 2550 |
| 2.9 | Overall Length (with Forks) | mm | 2940 | 3180 | 3180 | 3545 | 3620 |
| 2.10 | Fork Overhang | mm | 420 | 420 | 420 | 435 | 435 |
| 2.11 | Wheel Base | mm | 1400 | 1400 | 1400 | 1600 | 1600 |
| 2.12 | Real Overhang | mm | 350 | 440 | 440 | 440 | 515 |
| 2.13 | Min. Ground clearance (from Bottom of | mm | 110 | 110 | 110 | 128 | 128 |
| 2.14 | Overall Width | mm | 1070 | 1070 | 1070 | 1150 | 1150 |
| 2.15 | Lateral Fork Adjustment (Outside of Fork) (max./min.) | mm | 968/200 | 968/200 | 968/200 | 1024/240 | 1024/240 |
| 2.16 | Front Tread | mm | 890 | 890 | 920 | 970 | 970 |
| 2.17 | Rear Tread | mm | 920 | 920 | 920 | 970 | 970 |
| 2.18 | Min. Turning Radius(Outside) | mm | 1880 | 1955 | 1985 | 2170 | 2240 |
| 2.19 | Tilt of Mast Forward (deg) / Backward (deg) α / β | ° | 6/12 | 6/12 | 6/12 | 6/12 | 6/12 |
| 2.20 | Fork size | mm | 770*100*32 | 920*100*35 | 920*100*35 | 1070*120*40 | 1070*120*40 |
| Specification | | | | | | | |
| 3.1 | Travel Speed (laden/unladen) | km/h | 11.5/14.5 | 11.5/14.5 | 11.5/14.5 | 17/19.5 | 17/19.5 |
| 3.2 | Lifting Speed (laden/unladen) | mm/s | 590/650 | 590/650 | 590/650 | 570/600 | 570/600 |
| 3.3 | Self Weight | kg | 2150 | 2590 | 2820 | 3320 | 3680 |
| Tyre | | | | | | | |
| 4.1 | Number of Drive Wheels | | 2X/2 | 2X/2 | 2X/2 | 2X/2 | 2X/2 |
| 4.2 | Tyres Type | | Pneumatic | Pneumatic | Pneumatic | Pneumatic | Pneumatic |
| 4.3 | Dimensions of Front Wheels | | 6.50-10-10PR | 6.50-10-10PR | 6.50-10-10PR | 7.00-12-12PR | 7.00-12-12PR |
| 4.4 | Dimensions of Rear Wheels | | 5.00-8-8PR | 5.00-8-8PR | 5.00-8-8PR | 6.00-9-10PR | 6.00-9-10PR |
| Brake, Transmission Devices and Engine | | | | | | | |
| 5.1 | Battery Voltage/Capacity | V/Ah | 12/80 | 12/80 | 12/80 | 12/90 | 12/90 |
| | Engine Model | | Quanchai4B 4-45V32 or Optional | Quanchai4B 4-45V32 or Optional | Quanchai4B 4-45V32 or Optional | Xinchai4D27 G31(490) or Optional | Xinchai4D27 G31(490) or Optional |
| 5.3 | Rated Output/r.p.m | kW/rpm | 32/2500 | 32/2500 | 32/2500 | 36.8/2500 | 36.8/2500 |
| 5.4 | Rated Torque/r.p.m | N.m/rpm | 132/1800 | 132/1800 | 132/1800 | 156/1700-1900 | 156/1700-1900 |
| 5.5 | No. of Cylinder | | 4-80*100 | 4-80*100 | 4-80*100 | 4-90*105 | 4-90*105 |
| 5.6 | Displacement | L | 2.27 | 2.27 | 2.27 | 2.67 | 2.67 |
| 5.7 | Emission Standard | | China stage III or Optional | China stage III or Optional | China stage III or Optional | China stage III or Optional | China stage III or Optional |
| 5.8 | Fuel Tank Capacity | L | 38 | 38 | 38 | 60 | 60 |
| 5.9 | Transmissions Type | | Hydraulic | Hydraulic | Hydraulic | Hydraulic | Hydraulic |

| Characteristics | | | | | | | |
|--|---|---------|-----------------------------|-----------------------------|------------------------------|------------------------------|------------------------------|
| 1.1 | Model Name | Metric | FD30 | FD35 | FD40 | FD45 | FD50 |
| 1.2 | Power Source | | Diesel | Diesel | Diesel | Diesel | Diesel |
| 1.3 | Rated Capacity | kg | 3000 | 3500 | 4000 | 4500 | 5000 |
| 1.4 | Load Center | mm | 500 | 500 | 500 | 500 | 500 |
| Dimensions | | | | | | | |
| 2.1 | Mast Extended Height (with Brackrest) | mm | 4275 | 4270 | 4250 | 4250 | 4250 |
| 2.2 | Lifting Height | mm | 3000 | 3000 | 3000 | 3000 | 3000 |
| 2.3 | Mast Height, Lowered | mm | 2080 | 2125 | 2350 | 2350 | 2350 |
| 2.4 | Free Lift Height | mm | 145 | 150 | 150 | 150 | 150 |
| 2.5 | Backrest Height (Calculated from the Fork Surface) | mm | 1225 | 1220 | 1250 | 1250 | 1250 |
| 2.6 | Distance from the Surface of the Seat to the Overhead Guard | mm | 1035 | 1035 | 1020 | 1020 | 1020 |
| 2.7 | Overhead Guard Height | mm | 2106 | 2106 | 2350 | 2350 | 2350 |
| 2.8 | Overall Length (without Forks) | mm | 2690 | 2725 | 3195 | 3195 | 3195 |
| 2.9 | Overall Length (with Forks) | mm | 3760 | 3795 | 4265 | 4265 | 4265 |
| 2.10 | Fork Overhang | mm | 465 | 465 | 555 | 555 | 555 |
| 2.11 | Wheel Base | mm | 1700 | 1700 | 2100 | 2100 | 2100 |
| 2.12 | Real Overhang | mm | 525 | 560 | 540 | 540 | 584 |
| 2.13 | Min. Ground clearance (from Bottom of | mm | 145 | 145 | 175 | 175 | 175 |
| 2.14 | Overall Width | mm | 1225 | 1225 | 1420 | 1420 | 1420 |
| 2.15 | Lateral Fork Adjustment (Outside of Fork) (max./min.) | mm | 1091/250 | 1091/250 | 1340/300 | 1340/300 | 1340/300 |
| 2.16 | Front Tread | mm | 1000 | 1000 | 1180 | 1180 | 1180 |
| 2.17 | Rear Tread | mm | 970 | 970 | 1190 | 1190 | 1190 |
| 2.18 | Min. Turning Radius(Outside) | mm | 2420 | 2470 | 2600 | 2900 | 2900 |
| 2.19 | Tilt of Mast Forward (deg) / Backward (deg) α / β | ° | 6/12 | 6/12 | 6/12 | 6/12 | 6/12 |
| 2.20 | Fork size | mm | 1070*125* 45 | 1070*125* 50 | 1070*150* 50 | 1070*150* 50 | 1070*150* 50 |
| Specification | | | | | | | |
| 3.1 | Travel Speed (laden/unladen) | km/h | 18/19.5 | 18/19.5 | 22/22.5 | 22/22.5 | 22/22.5 |
| 3.2 | Lifting Speed (laden/unladen) | mm/s | 450/500 | 380/450 | 370/400 | 370/400 | 460/500 |
| 3.3 | Self Weight | kg | 4370 | 4750 | 5950 | 6200 | 6400 |
| Tyre | | | | | | | |
| 4.1 | Number of Drive Wheels | | 2X/2 | 2X/2 | 2X/2 | 2X/2 | 2X/2 |
| 4.2 | Tyres Type | | Pneumatic | Pneumatic | Pneumatic | Pneumatic | Pneumatic |
| 4.3 | Dimensions of Front Wheels | | 28*9-15-12PR | 28*9-15-12PR | 300-15-14PR | 300-15-14PR | 300-15-14PR |
| 4.4 | Dimensions of Rear Wheels | | 6.50-10-10PR | 6.50-10-10PR | 7.00-12-12PR | 7.00-12-12PR | 7.00-12-12PR |
| Brake, Transmission Devices and Engine | | | | | | | |
| 5.1 | Battery Voltage/Capacity | V/Ah | 12/80 | 12/80 | 24/90 | 12/90 | 12/90 |
| 5.2 | Engine Model | | Xinchai 4D27G31 or Optional | Xinchai 4D27G31 or Optional | Xinchai 4D35ZG31 or Optional | Xinchai 4D35ZG31 or Optional | Xinchai 4D35ZG31 or Optional |
| 5.3 | Rated Output/r.p.m | kW/rpm | 36.8/2500 | 36.8/2500 | 48/2300 | 48/2300 | 48/2300 |
| 5.4 | Rated Torque/r.p.m | N.m/rpm | 156/1700-1900 | 156/1700-1900 | 230/1600-1800 | 230/1600-1800 | 230/1600-1800 |
| 5.5 | No. of Cylinder | | 4-90*105 | 4-90*105 | 4 | 4 | 4 |
| 5.6 | Displacement | L | 2.67 | 2.67 | 3.47 | 3.47 | 3.47 |
| 5.7 | Emission Standard | | China stage III or Optional | China stage III or Optional | China stage III or Optional | China stage III or Optional | China stage III or Optional |
| 5.8 | Fuel Tank Capacity | L | 60 | 60 | 90 | 60 | 60 |
| 5.9 | Transmissions Type | | Hydraulic | Hydraulic | Hydraulic | Hydraulic | Hydraulic |

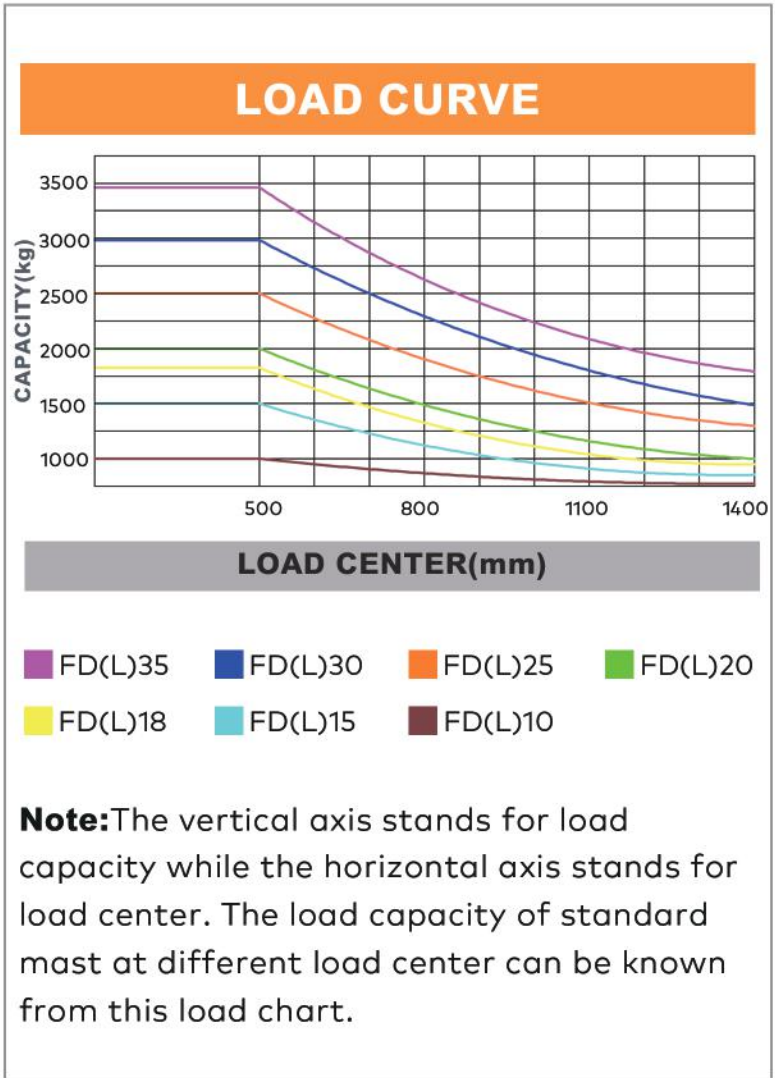
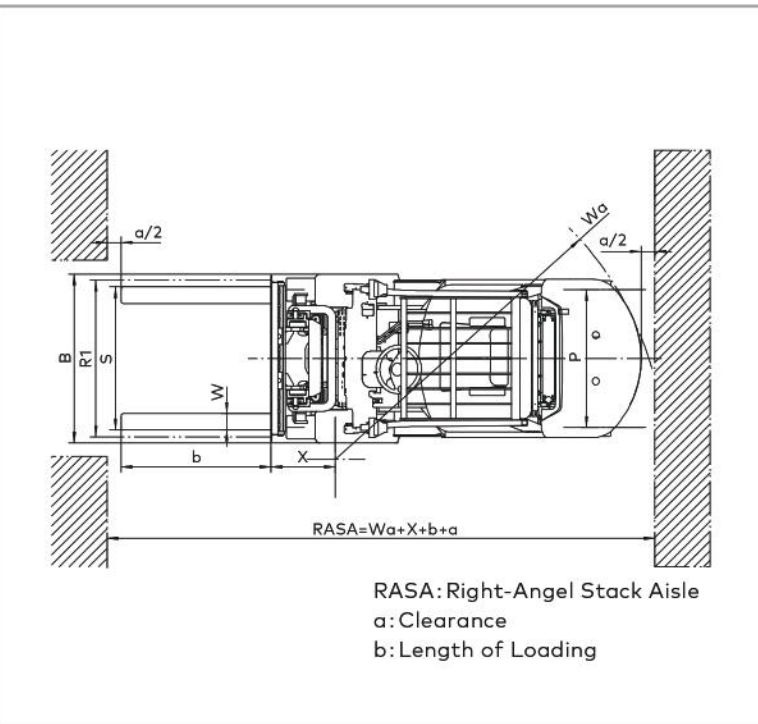
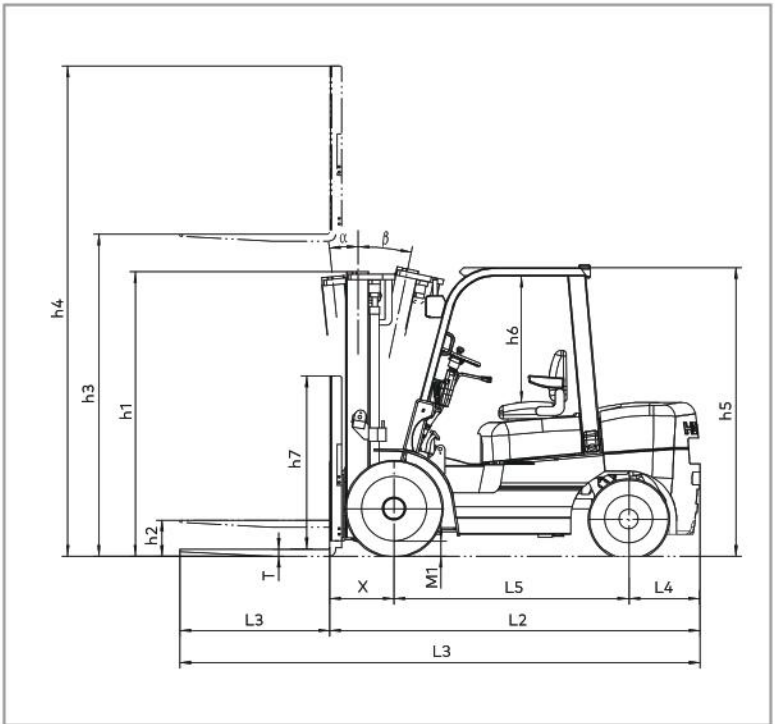

- ### Standard Configuration
- Fork | Water Thermometer | Load Backrest |
 - Overhead Guard | Electric Horn | Traction Pin | Fuel Gauge | Two-piece Multi-way Valve |
 - Transmission Oil Filter Cartridge | Reversing Buzzer |
 - Transmission Oil Dipstick | Neutral Safety Switch |
 - Overhead Guard Rain-cover | Air Intake Device |
 - Durable Patterned | Tool Box | Wide-view Mast |
 - Standard Seat | Headlamp | Rear Combined Lamp |
 - Shaped Pedal Pad | Hydraulic Oil Dipstick |
 - Lifting and Tilt Lever | Tilt Adjustable Steering Column
- ### Optional Configuration
- Driver's Cabin | Warning Light | Upper Exhaust | Heater |
 - Full Free 2-Stage Mast | Full Free 3-Stage Mast |
 - Special Size Fork | Side Shifter | Paper Roller Clamp |
 - Brick Clamp | Rotator | Push-puller | Fork Positioner |
 - Other Japanese Engines | Cooling Air Conditioner |
 - Suspension Seat | Solid Tyre | Fire Extinguisher |
 - Rear Working Light | Cylinder Sleeve | Full LED Lights |
 - OPS (Travelling Function and Loading Function)

Representantes para Colombia y Ecuador
 Calle 35 B sur 72L 61
 Bogotá D.C - Colombia
www.mixingyequipos.com
 +57 (601)-7048674 / +57 - 313 715 1638
 / 320 492 5574 / 320 900 3321